



Product Description:

- Bag Dispenser - Double
- Holds two rolls of bags (up to 9.50" long and 3.40" in diameter)
- Two-way keyholes for vertical or horizontal wall mounting
- Made of Quartz Beige Powder-Coated Aluminum

Primary Area for Product Usage:

- Any location which requires bags for storage or refuse at the point of use: laboratory, food service, O.R., clinical areas, dental, veterinary

Dispenses:

- Two rolls of individual-sized biohazard, linen, or refuse bags
- Rolls no larger than 9.50"W x Ø3.40" (24.1 cm x 8.6 cm)

Package Specifications:

- Package Quantity: 6 per case
- 16"L x 12"W x 12"H (40.6 cm x 30.5 cm x 30.5 cm)
- 10.0 lbs (4.5 kg) - approximated

Product Specifications (overall external dimensions):

- 10.05"W x 7.00"H x 3.90"D (25.5 cm x 17.8 cm x 9.9 cm)
- 1.3 lbs (0.6 kg) - approximated

Mounting Specifications:

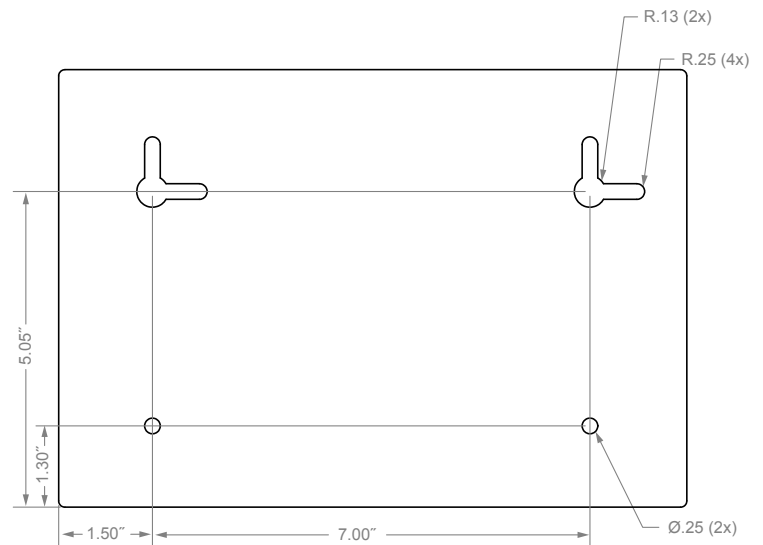

Advantage

Designed for Long-Term Use

Our aluminum dispensers and stands are coated with polyester triglycidyl isocyanurate (TGIC) powders, making them highly corrosion resistant. They are lightweight, attractive, functional and provide years of service.

Major Benefits

Durable

Our powder-coated aluminum dispensers resist corrosion, chipping, and flaking. This material will provide long-lasting products that hold up well, even in tough environments.

Cleaning

The semi-gloss powder-coated finish resists mild chemicals and cleaning agents, such as Windex or glass cleaners. Standard hospital cleaning supplies are approved for use on our powder-coated products or can be cleaned with a damp cloth or mild soap and water. Scotch-Brite, steel wool or any abrasive products should not be used.

Strength

Powder-coated aluminum is ideal for dispensers used in a healthcare or industrial settings. It is impact resistant and is not affected by extremes in temperature.

Appearance

The clean, bright appearance of powder-coated aluminum looks attractive and provides a professional image in all environments.

