



### Product Description:

- Bag Dispenser - Single - Large Capacity
- Holds a single roll of bags (up to 12.00" long and 6.00" diameter)
- Two-way keyholes for vertical or horizontal wall mounting (Please note: For bags heavier than 4.5 lbs., dispenser should be mounted vertically to adequately disperse roll weight and allow for proper bag dispensing.)
- Made of Quartz Beige Powder-Coated Aluminum

### Primary Area for Product Usage:

- Any location which requires bags for storage, protection, or refuse at the point of use: laboratory, food service, O.R., clinical areas, dental, veterinary

### Dispenses:

- Single roll of individual-sized biohazard, linen, or refuse bags, or cart covers
- Roll no larger than 12.00"W x Ø6.00" (30.5 cm x 12.7 cm)

### Package Specifications:

- Package Quantity: 4 per case
- 20"W x 16"H x 12"D (50.8 cm x 40.6 cm x 30.5 cm)
- 9.0 lbs (4.1 kg) - approximated

### Product Specifications (overall external dimensions):

- 12.00"W x 6.35"H x 6.40"D (30.5 cm x 16.1 cm x 16.3 cm)
- 1.6 lbs (0.7 kg) - approximated

### Mounting Specifications:

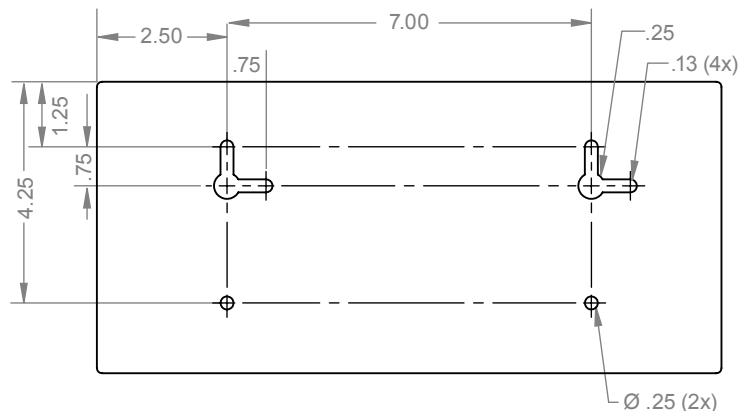



1

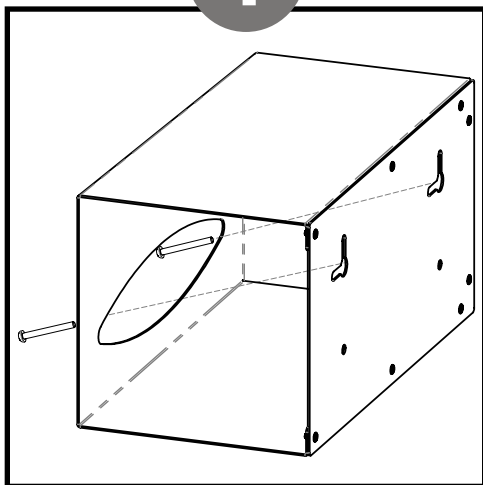

Whether mounting vertically or horizontally, first measure and install two screws approved and provided by maintenance for keyhole placement on the dispenser.

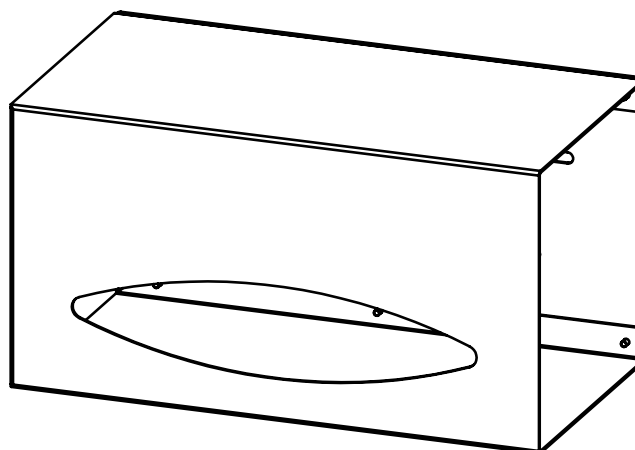

2

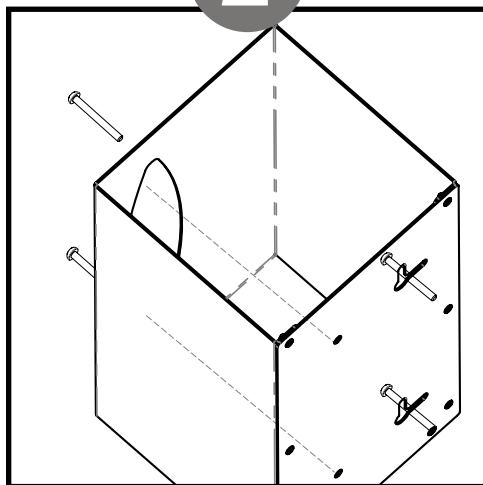

Mount the empty dispenser through the keyholes to surface-installed screws and tighten using a flexible screwdriver. Install two additional screws in dispenser's screw holes.

3

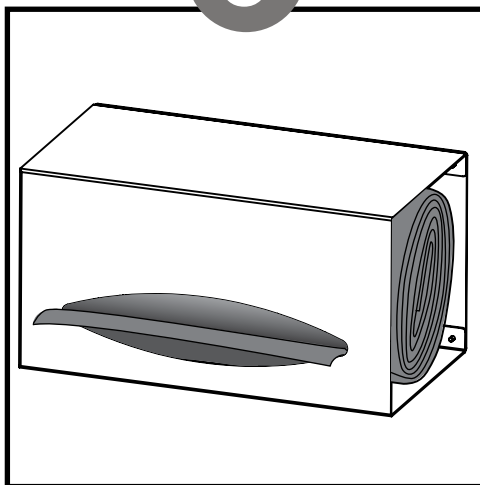

Insert bag roll so the dispensing bag is coming from the bottom of the roll.

4

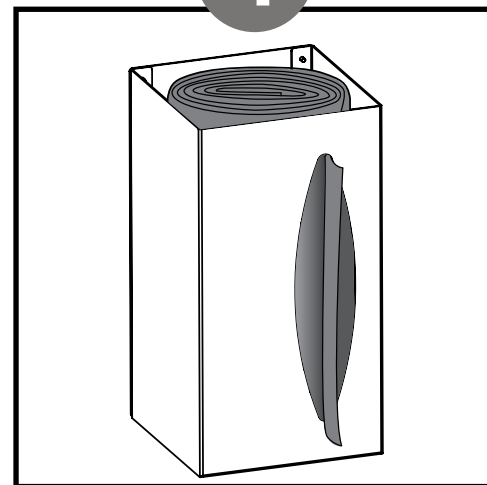

For bags weighing over 4.5 lbs., mount the dispenser vertically. Load the bag roll so the bags pull from the right side as shown.

#### Parts included:

- Dispenser

#### Tools required:

- No tools required to assemble dispenser



## Advantage

### Designed for Long-Term Use

Our aluminum dispensers and stands are coated with polyester triglycidyl isocyanurate (TGIC) powders, making them highly corrosion resistant. They are lightweight, attractive, functional and provide years of service.

## Major Benefits

### *Durable*

Our powder-coated aluminum dispensers resist corrosion, chipping, and flaking. This material will provide long-lasting products that hold up well, even in tough environments.

### *Cleaning*

The semi-gloss powder-coated finish resists mild chemicals and cleaning agents, such as Windex or glass cleaners. Standard hospital cleaning supplies are approved for use on our powder-coated products or can be cleaned with a damp cloth or mild soap and water. Scotch-Brite, steel wool or any abrasive products should not be used.

### *Strength*

Powder-coated aluminum is ideal for dispensers used in a healthcare or industrial settings. It is impact resistant and is not affected by extremes in temperature.

### *Appearance*

The clean, bright appearance of powder-coated aluminum looks attractive and provides a professional image in all environments.

