



Rear View



MADE IN THE USA

Product Description:

- Glove Box Dispenser - Single with Flexible Spring - Cabinet Mount
- Holds one box of gloves
- Flexible spring on back pushes box forward to cabinet opening
- Front screw holes for mounting inside a cabinet
- Made of White Powder-Coated Steel

Primary Area for Product Usage:

- All primary care areas: clinic/exam rooms, radiology, labs, physical therapy, O.R. areas, employee health
- Kitchens, laundry facilities, environmental services, sterile processing

Dispenses:

- Most brand name standard glove boxes
- Boxes no larger than 5.50"W x 10.00"H x 3.69"D (14.0 cm x 25.4 cm x 9.4 cm)

Package Specifications:

- Package Quantity: 12 per case
- 18"L x 16"W x 10"H (45.7 cm x 40.6 cm x 25.4 cm)
- 20.0 lbs (9.1 kg) - approximated

Product Specifications (overall external dimensions):

- 5.60"W x 10.00"H x 3.80"D (14.2 cm x 25.4 cm x 9.7 cm)
- 1.4 lbs (0.6 kg) - approximated

Mounting Specifications:

Alternate Products (each sold separately):

- Glove Box Dispenser - Single with Flexible Spring, GL100-1214
- Glove Box Dispenser - Single with Flexible Spring, GL100-0212
- Glove Box Dispenser - Triple with Dividers, GL300-1214
- Glove Box Dispenser - Triple with Dividers, GL300-0212

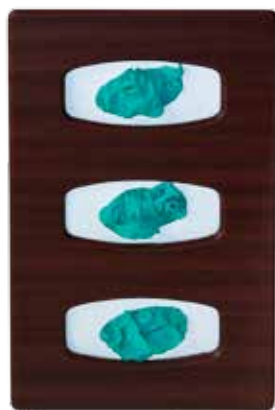

GL300-1214

Mounted inside a precut cabinet, shown from front



GL300-1214

Mounted inside a precut cabinet, shown from rear

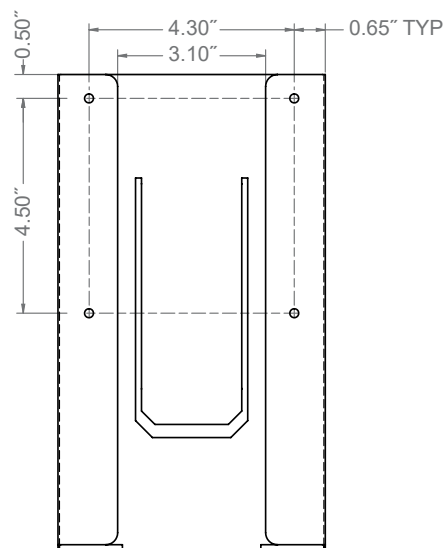



Installation

Always mount dispensers securely *prior* to loading with product.

- Pre-cut dispensing holes in a cabinet door, up to 3.10"W x 10.00"H.

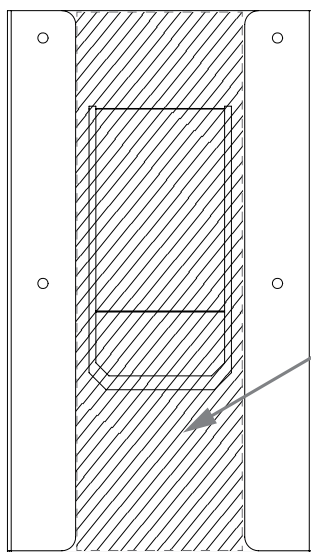

Available cut area
for dispensing

1

- Attach dispenser to inside of cabinet door, using screws recommended and provided by building maintenance.

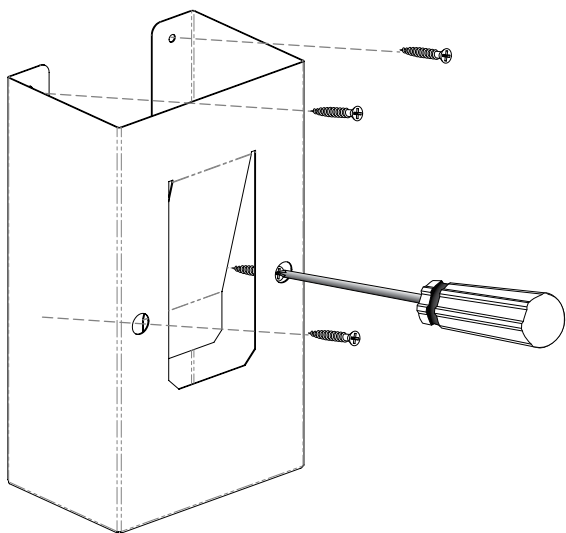

2

Parts included:

- Dispenser

Tools Required:

- No tools required to assemble dispenser

Characteristics & Care

Powder-Coated Steel

Material Characteristics

Designed for Long-Term Use

Our steel dispensers and stands are coated with polyester powders which makes them highly resistant to corrosion.

Powder-coated steel is ideal for dispensers used in a healthcare or an industrial setting because it is impact resistant and is not effected by extremes in temperature.

Dispensers and stands made of powder-coated steel are both attractive and functional, providing years of service.

Care and Cleaning

For best results, clean by washing the surface with a diluted solution of a mild, non-abrasive detergent in cold or warm water and a non-abrasive cloth. Standard hospital cleaning supplies can be used.

Dry with a soft cloth. Do not use any solvent-based materials, abrasives (e.g. Scotch-brite, steel wool), or apply excessive force during cleaning.