



Product Description:

- Glove Box Dispenser - Double with dividers
- Holds two boxes of gloves
- Three-way keyholes for vertical or horizontal wall mounting
- BOWMAN® *Signature Series* - Made of Maple Fauxwood ABS plastic (also available in Cherry Fauxwood ABS plastic, GL020-0233)

Primary Area for Product Usage:

- All primary care areas: clinic/exam rooms, radiology, labs, physical therapy, O.R. areas, environmental services

Dispenses:

- Most brand name standard glove boxes no larger than 5.50"W x 10.00"H x 3.75"D (14.0 cm x 25.4 cm x 9.5 cm)

Package Specifications:

- Package Quantity: 6 per case
- 16"L x 12"W x 12"H (40.6 cm x 30.5 cm x 30.5 cm)
- 9.0 lbs (4.1 kg) - approximated

Product Specifications (overall external dimensions):

- 11.38"W x 10.13"H x 4.00"D (28.9 cm x 25.7 cm x 10.2 cm)
- 1.15 lbs (0.5 kg) - approximated

Mounting Specifications:

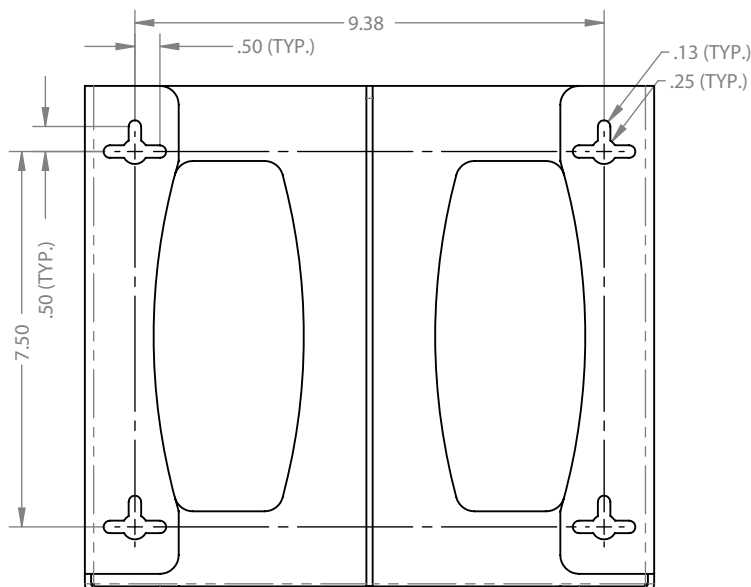



1

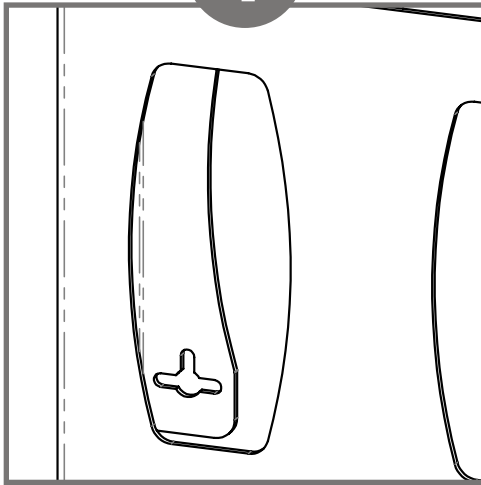

Unique shape of openings helps prevent over dispensing product.

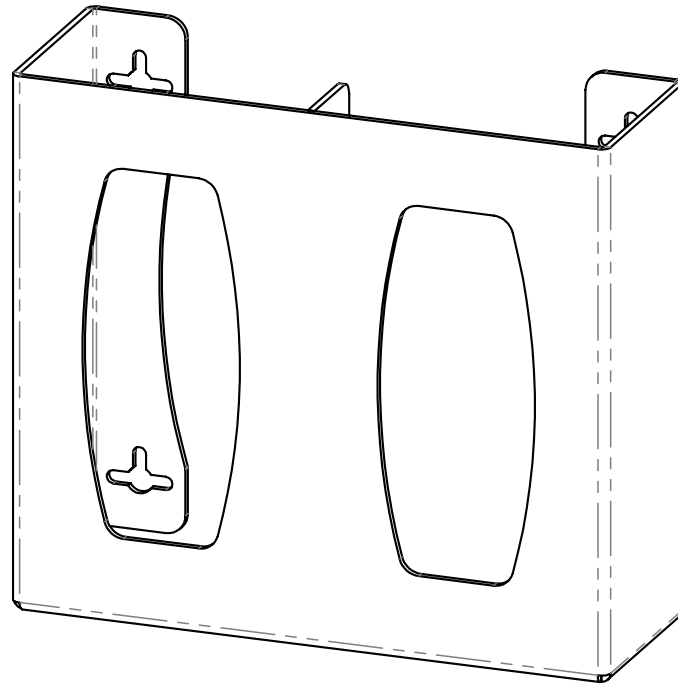

2

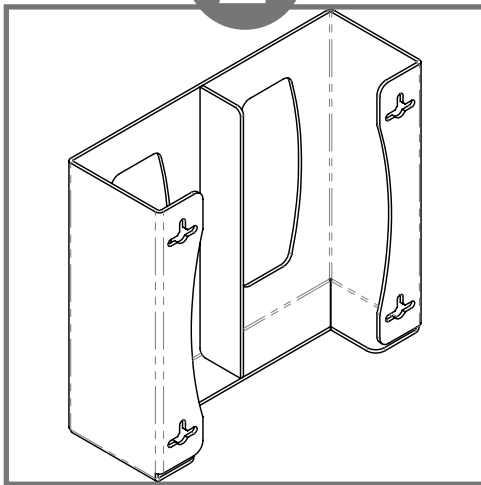

Dividers keep glove boxes separate, easy to load, and stable without compromising aesthetics or effectiveness.

3

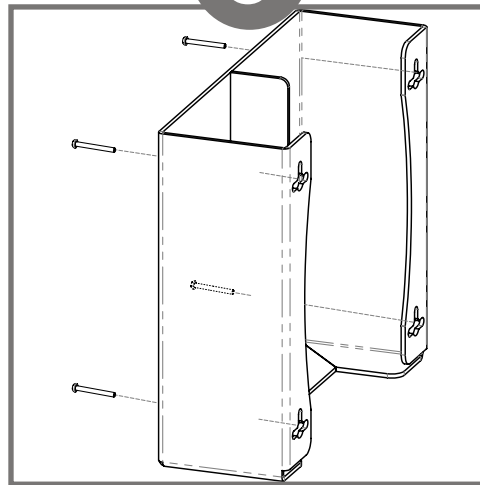

Dispenser should be mounted securely to a wall through keyholes in back with screws approved and provided by building maintenance.

Parts included:

- Dispenser

Tools required:

- No tools required to assemble glove box dispenser



Advantage

Designed for Long-Term Heavy-Duty Applications

The combination of copolymers (Acrylonitrile, Butadiene, and Styrene) gives ABS an excellent combination of strength, rigidity, and toughness. The fauxwood finish is ARVINYL laminate created from a semi-rigid film.

Major Benefits

Durable

ABS is chemical and stress-crack resistant. It is tough, dimensionally stable, and will hold up to long-term use. To ensure product longevity, fauxwood products should not be mounted in very hot or cold areas.

Cleaning

BOWMAN® *Signature Series* products can be cleaned with standard hospital cleaning products. Petroleum-based oils, solvents, and paints should not be used.

Strength

ABS plastic possesses high strength and performance characteristics at a reasonable cost. These qualities make it perfect for a wide variety of applications, including medical and laboratory equipment.

Appearance

Our fauxwood material is engineered to have a natural grain appearance both in Cherry and Maple finishes. The two color choices provide a visually appealing, upscale option to any area.

