



Above: Shown with Sign Holder, MP-047 (sold separately)  
Below: Using shelf area for boxed N-95 face masks



### Product Description:

- Protection System
- Holds a variety of gowns, three boxes of gloves, one box of earloop-style face masks, one box of shield-style face masks, and built-in storage area (for a variety of medical supplies, fourth box of gloves, or one box of N-95 face masks)
- Keyholes for wall mounting or may be used with a BOWMAN® door or wall hanger
- Made of quartz ABS plastic

### Primary Area for Product Usage:

- All patient care areas requiring personal protective equipment and isolation supplies, including oncology clinics, dialysis centers and clinic exam areas

### Dispenses:

- Top left section: Gowns folded up to 14.9"W x 4.5"D
- Top right section: One box of shield-style face masks up to 8.1"W x 9.9"H x 4.5"D
- Middle right section: One box of earloop-style face masks up to 8.0"W x 5.3"H x 4.5"D
- Four bottom sections: Four glove boxes up to 11.5"W x 5.5"H x 4.5"D, or three glove boxes and miscellaneous medical supplies in bottom right

### Accessories (sold separately):

- Sign Holder MP-047
- BOWMAN® door and wall hangers: MB-450, MB-500, MB-510, and MB-600
- Clip-On Caddy Dispensers: MP-015 and MP-085

### Package Specifications:

- 27"L x 8"W x 32"H (68.6 cm x 20.3 cm x 81.3 cm)
- 12 lbs (5.4 kg) - approximated

### Product Specifications (overall external dimensions):

- 23.38"W x 26.63"H x 4.75"D (59.4 cm x 67.6 cm x 12.1 cm)
- 7.8 lbs (3.5 kg) - approximated

### Mounting Specifications:

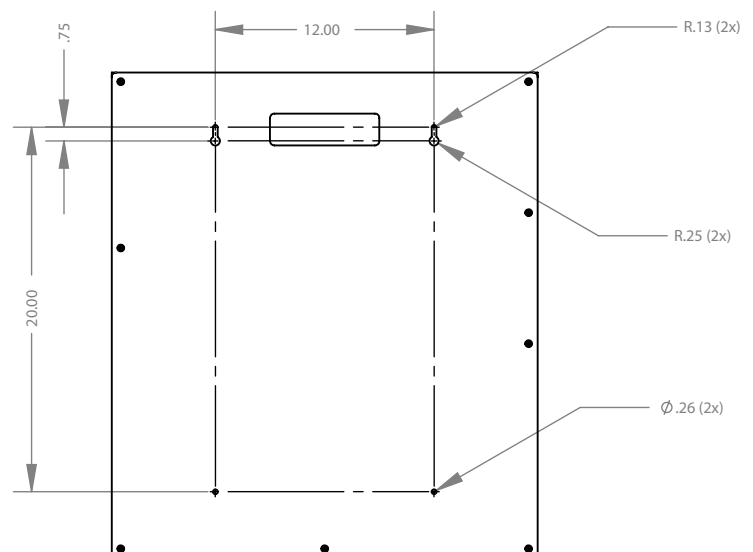

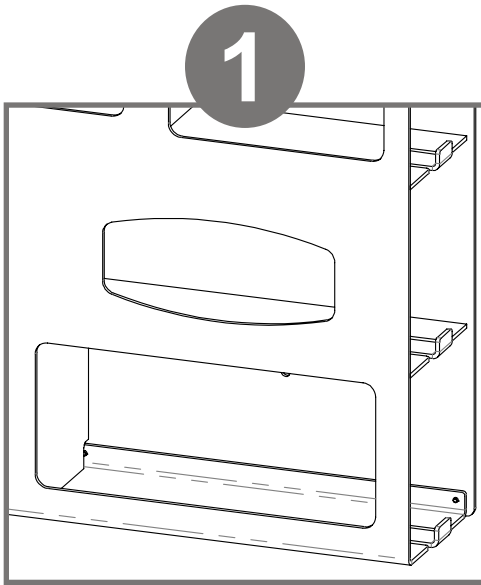

Open section at lower right can be used to store a variety of boxed or loose medical supplies.

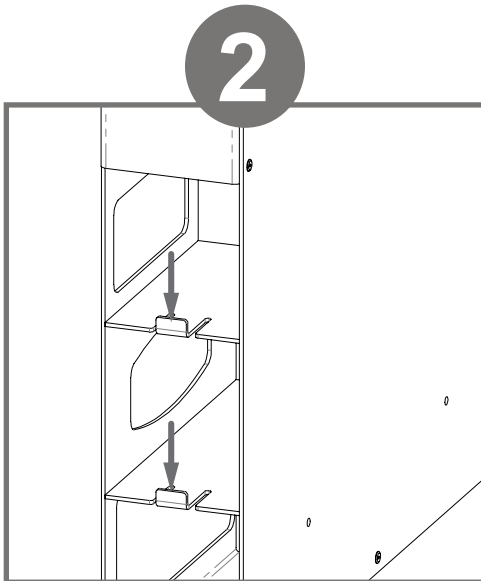
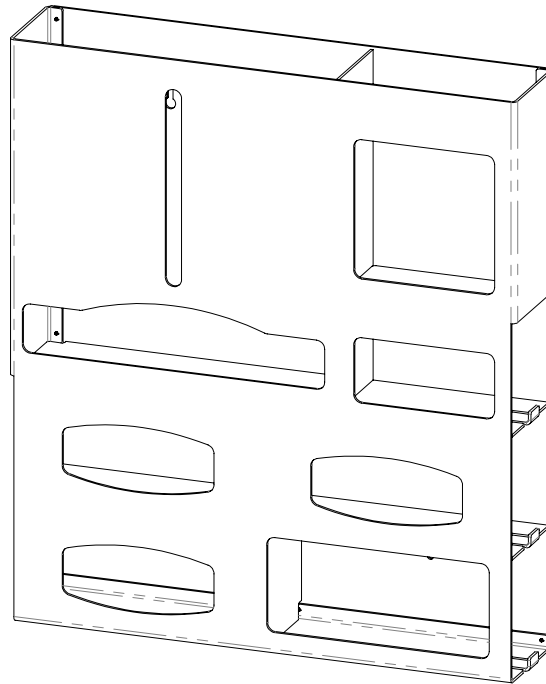

The flexible tabs on the side are designed to hold product securely in the dispenser. To add or remove product, press down on the tab and pull box out.

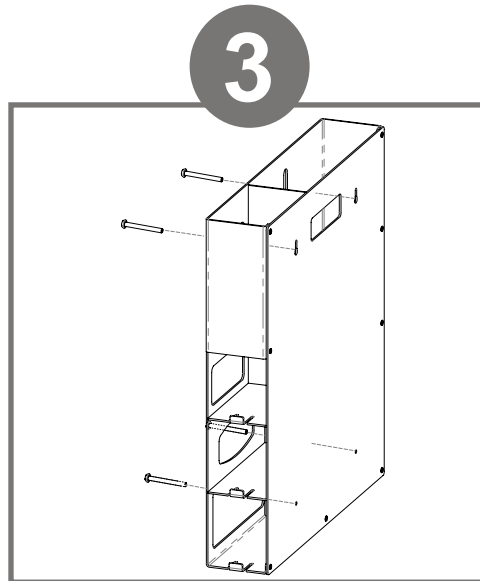

Dispenser should be mounted securely to a wall through keyholes in back with screws approved and provided by building maintenance.

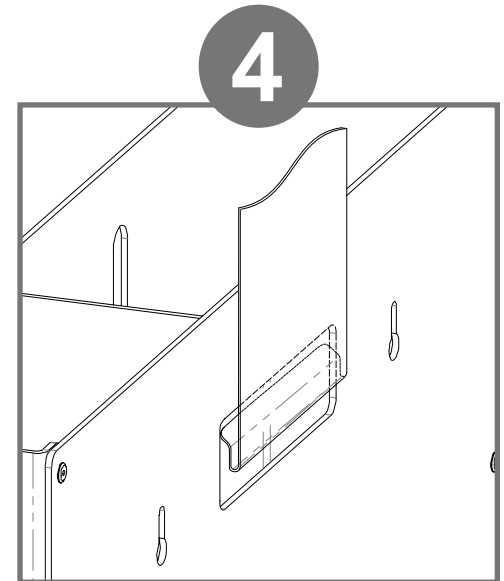

Alternatively, dispenser can be attached to a surface by hanging on a BOWMAN® door or wall hanger (sold separately) through the cut-out on the back of the dispenser.

### Parts included:

- Protection system

### Tools required:

- No tools required to assemble system



## Advantage

### Designed for Long-Term Heavy-Duty Applications

The combination of copolymers (Acrylonitrile, Butadiene, and Styrene) gives ABS an excellent combination of strength, rigidity, and toughness.

## Major Benefits

### *Durable*

ABS is chemical and stress-cracking resistant. It is tough, dimensionally stable, and will hold up to long-term use.

### *Cleaning*

Use mild soap and water to clean. Petroleum-based oils, solvents, and paints should not be used.

### *Strength*

ABS plastic possesses high strength and performance characteristics at a reasonable cost. These qualities make it perfect for a wide variety of applications, including medical and laboratory equipment.

### *Appearance*

The quartz, lightly textured finish has a clean, attractive look.

